

# Data sheet 50UTZ2.75S-51

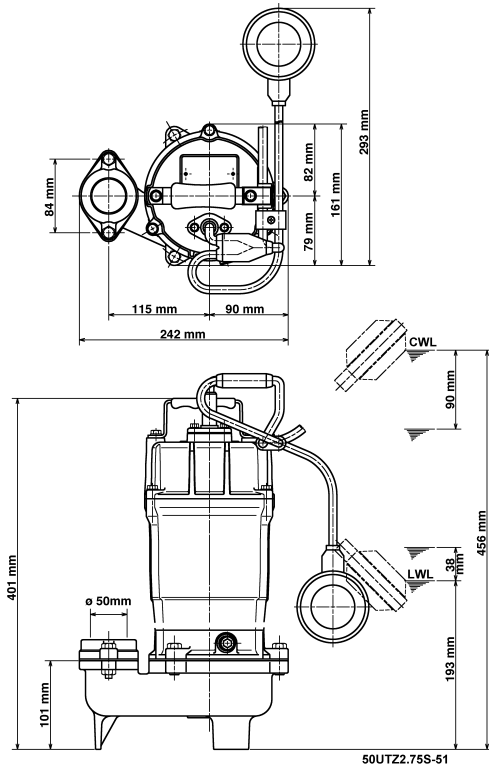

CWL: Continuous running water level  
 LWL: Lowest running water level

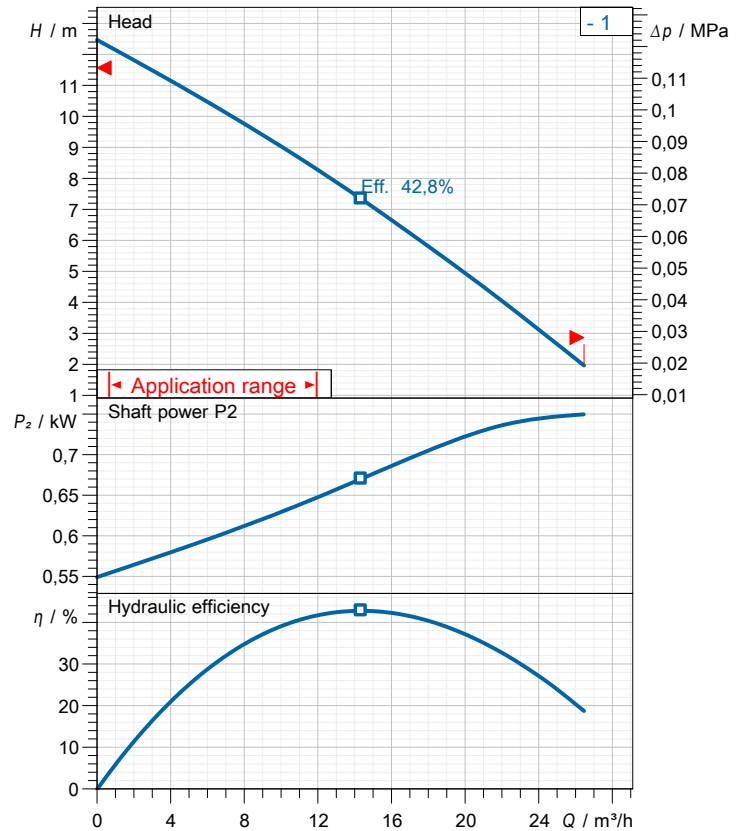

## Specification

Elektrische Tauchpumpe UT-Serie  
 Degree of protection IP 68  
 Pressure resistance max. 10 m  
 Type of impeller Vortex impeller  
 Free passage 35 mm  
 Suitable for:  
 waste water and liquid carrying

## Electric motor

Dry-type submersible induction motor  
 Insulation class E 2Poles 2824 1/min  
 Starting mode  
 Rated voltage 230 V 50 Hz 1~  
 Power uptake 1,14 kW  
 Rated power 0,75 kW  
 Rated current 5 A  
 Start current

## Cable

10m H07RN-F 3Cx1mm²

## Motor Protection

Circle thermal protector  
 (snap-action bi-metal device)

## Shaft seal

Double inside mechanical seal in oil bath  
 additional lubrication by oil lifting device  
 Primary seal  
 Silicon carbide on ceramic  
 Secondary seal  
 Ceramic on carbon

## Bearings

Shielded ball bearings, maintenance-free

## Materials

Impeller	PPO-GF20
Pump casing	FC200 (EN-GJL-200)
Motor Frame	FC200 (EN-GJL-200)
Shaft	SUS403 (EN-X6Cr13)

## Discharge size

2" (50mm) screwed-in mating flange

## Weight

17 kg (dry weight of the pump only without cable)

# Performance curve

## 50UTZ2.75S-51

Discharge port	2"
FördH	12,5 m
Flow	26,5 m³/h
Rated power	0,75 kW
Power input	1,14 kW
Phases	1~
Voltages	230 V
Frequency	50 Hz
Rated current	5 A
Starting current	
Number of poles	2
Speed	2824 1/min
Starting mode	
Insulation class	E

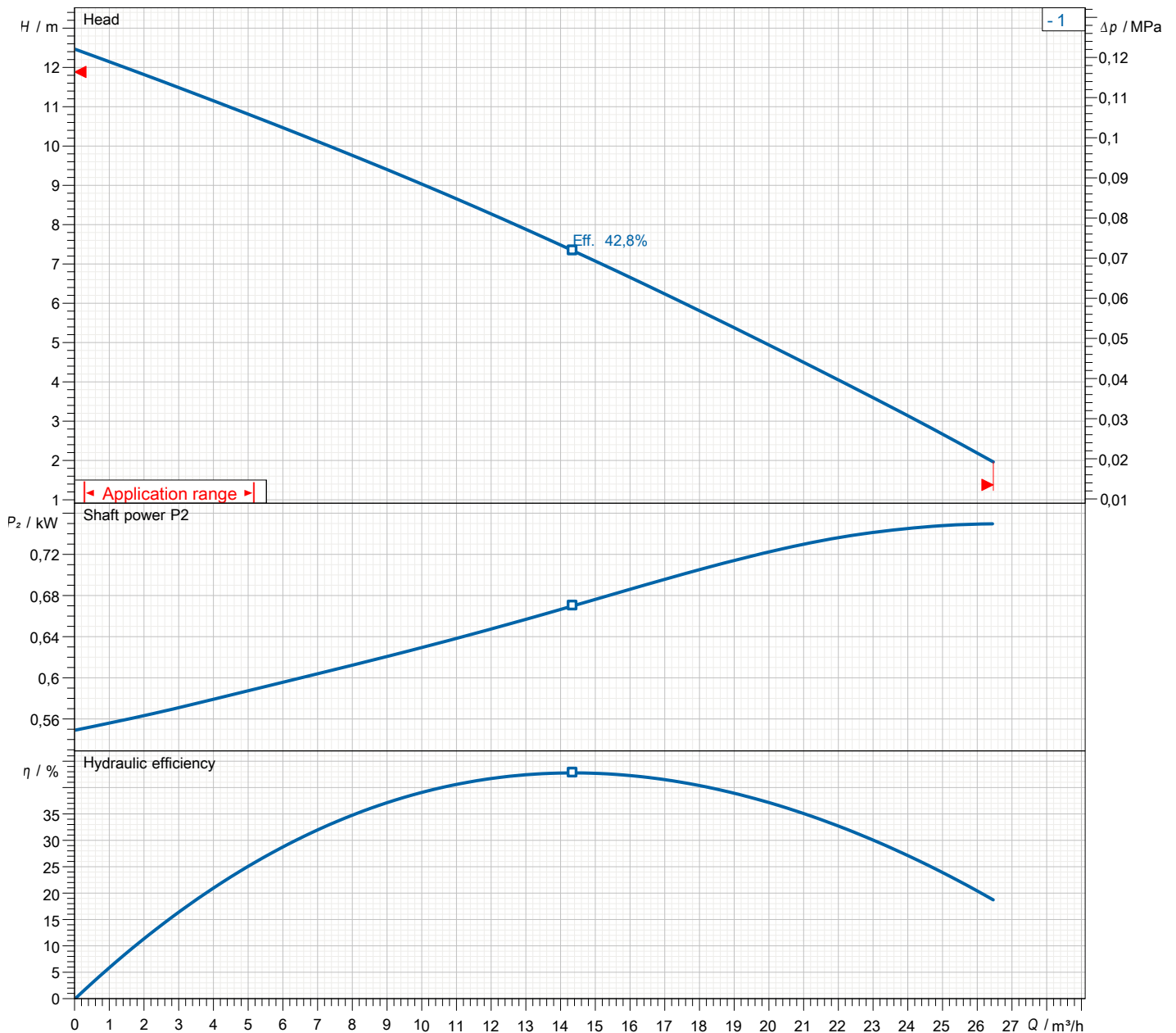

# Dimensions

## 50UTZ2.75S-51

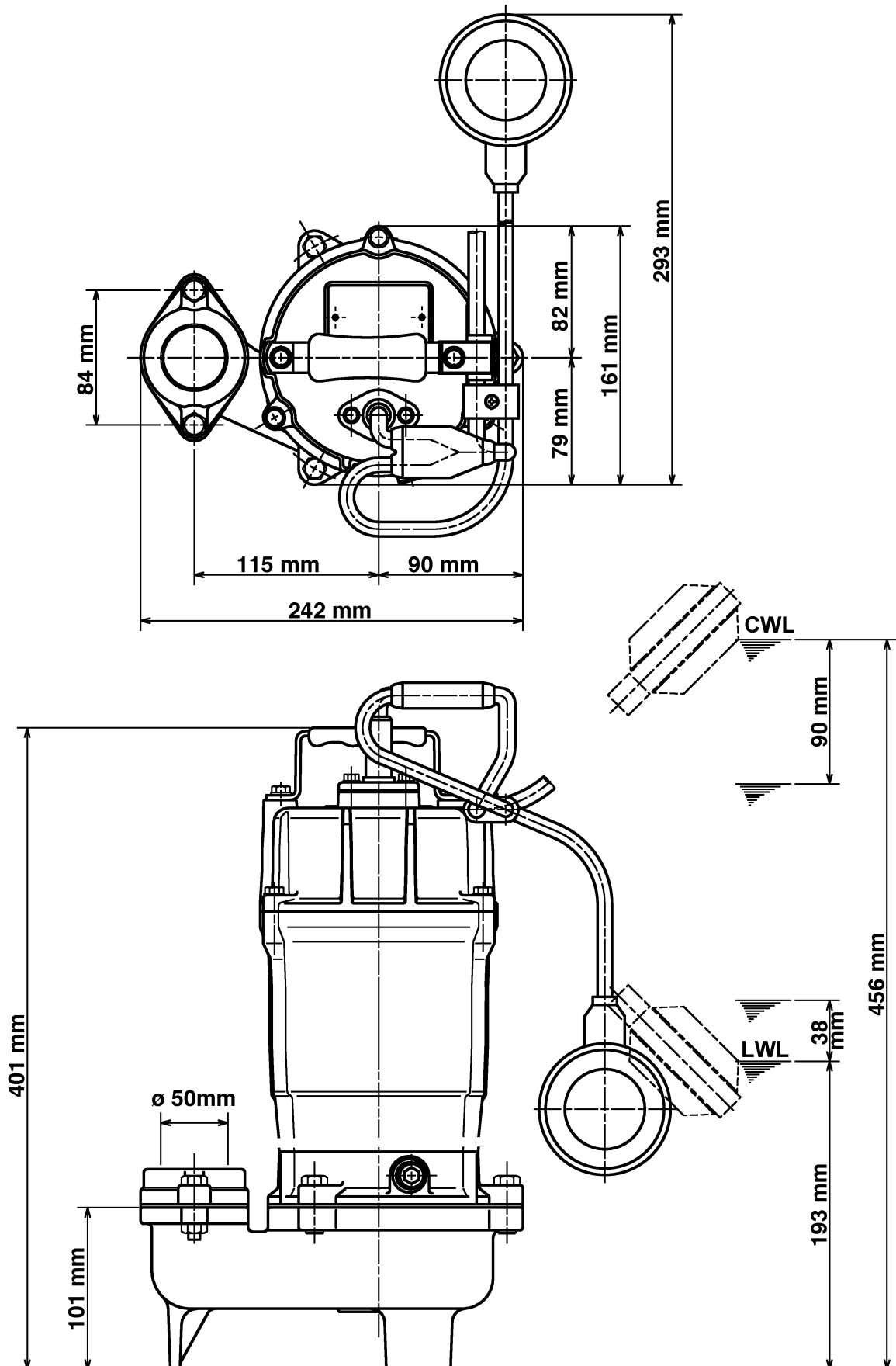

50UTZ2.75S-51

CWL: Continuous running water level  
LWL: Lowest running water level

# Sectional drawing

## 50UTZ2.75S-51

No.	Description	Remark	No.	Description	Remark
1	Cable	H07RN-F	56	Stator	.
20	Pump casing	FC200 (EN-GJL-200)	64	Motor Frame	FC200 (EN-GJL-200)
21	Impeller	PPO-GF20	68	Handle	Synthetic resin
25	Mechanical seal	W-14VL	71	Shaft protection sleeve	SUS304 (EN-X5CrNi18-10)
29	Oil casing	FC200 (EN-GJL-200)	76	Capacitor	.
30	Oil distributor	Plastic			
35	Oil screw	SUS304 (EN-X5CrNi18-10)			
36	Lubricant	Turbine oil (ISO VG32)			
48	Screwed Flange	FC200 (EN-GJL-200)			
50	Motor cover	FC200 (EN-GJL-200)			
51	Main cover	FC200 (EN-GJL-200)			
52A	Upper bearing	6201ZZC3			
52B	Lower bearing	6202ZZC3			
53	Motor Protector 380/400/415V-50Hz	KA314-HRXL00 (H.C)			
54	Shaft	SUS403 (EN-X6Cr13)			
55	Rotor	.			